

# BUREAU ELECTRIQUE EXTREM

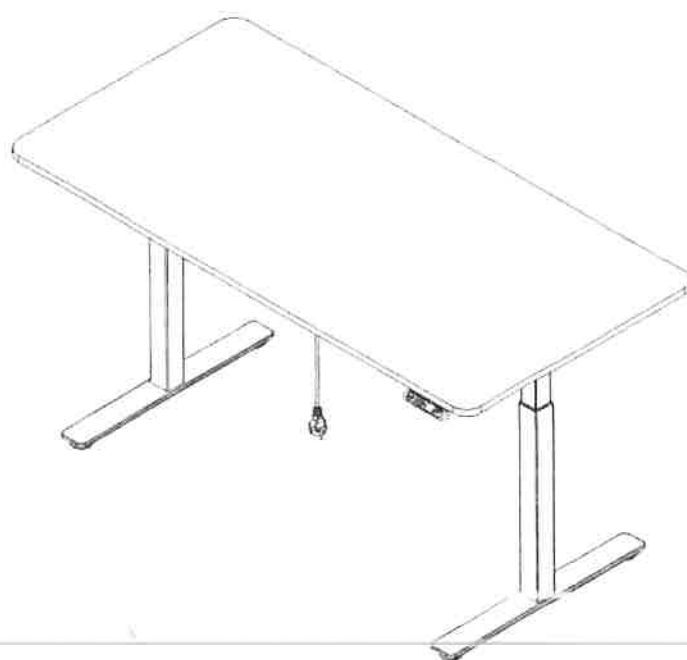

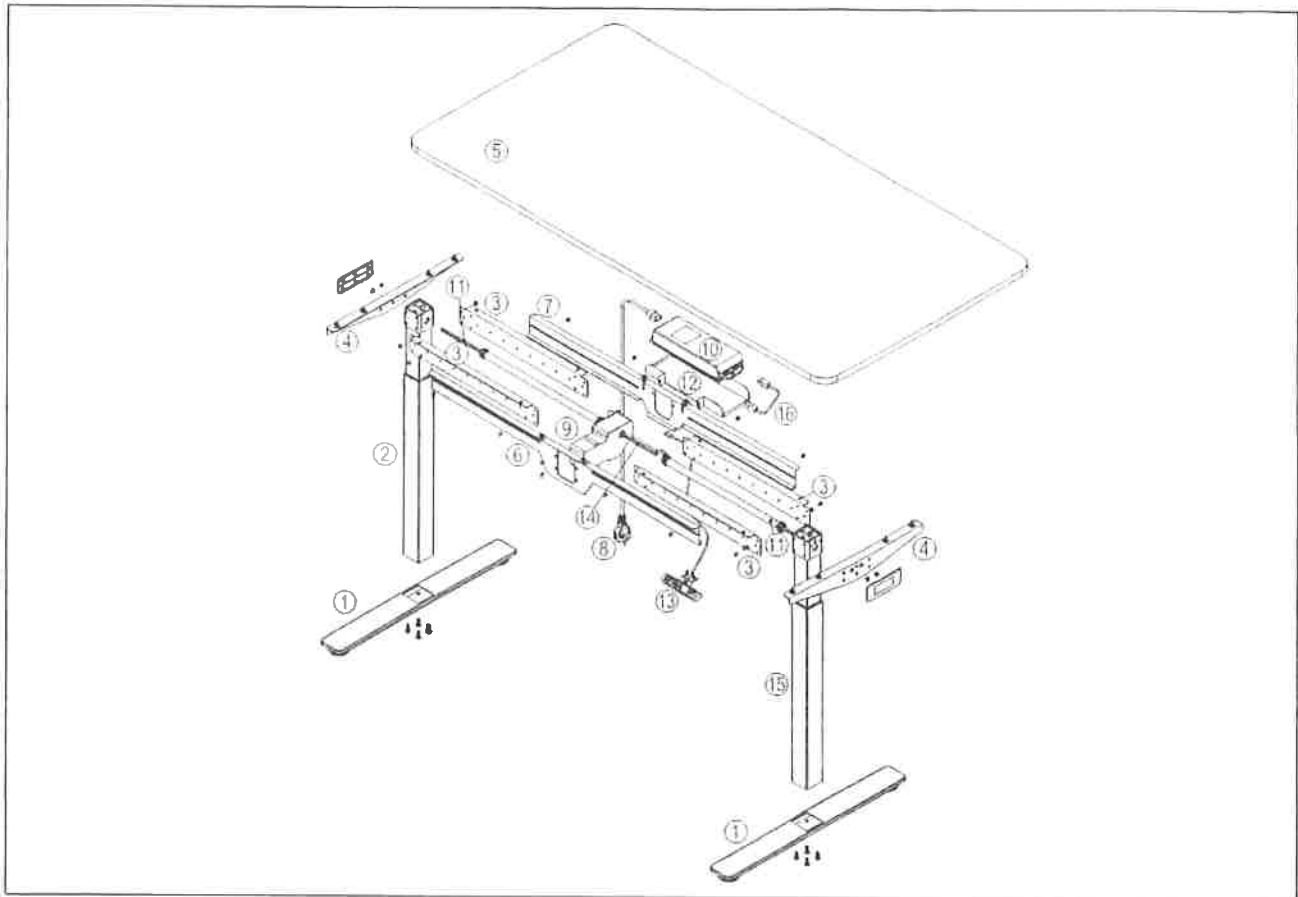

Step 1

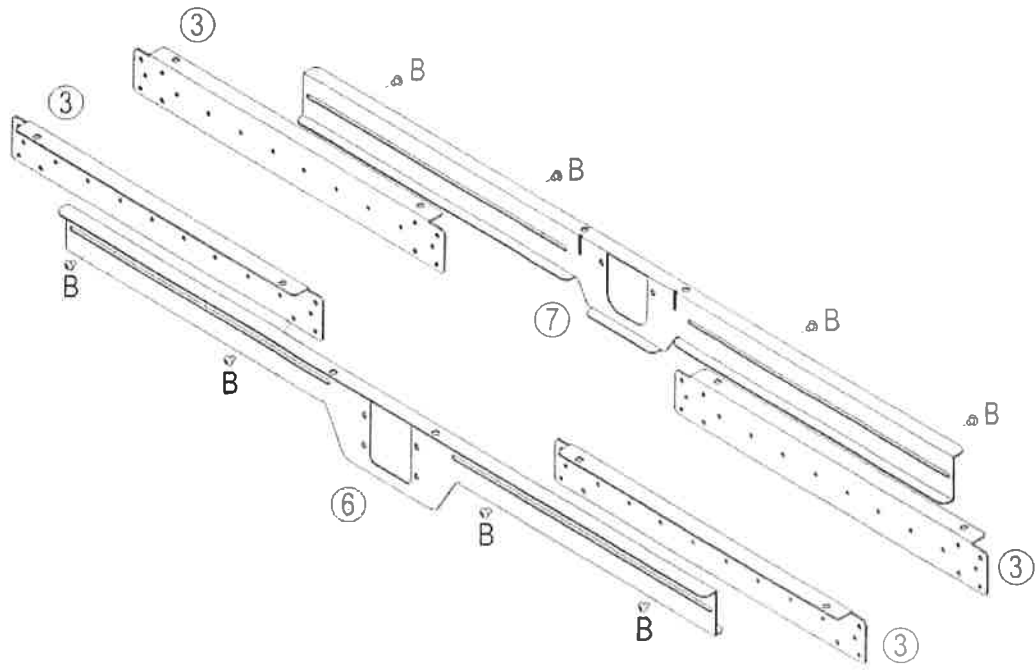

Step 2

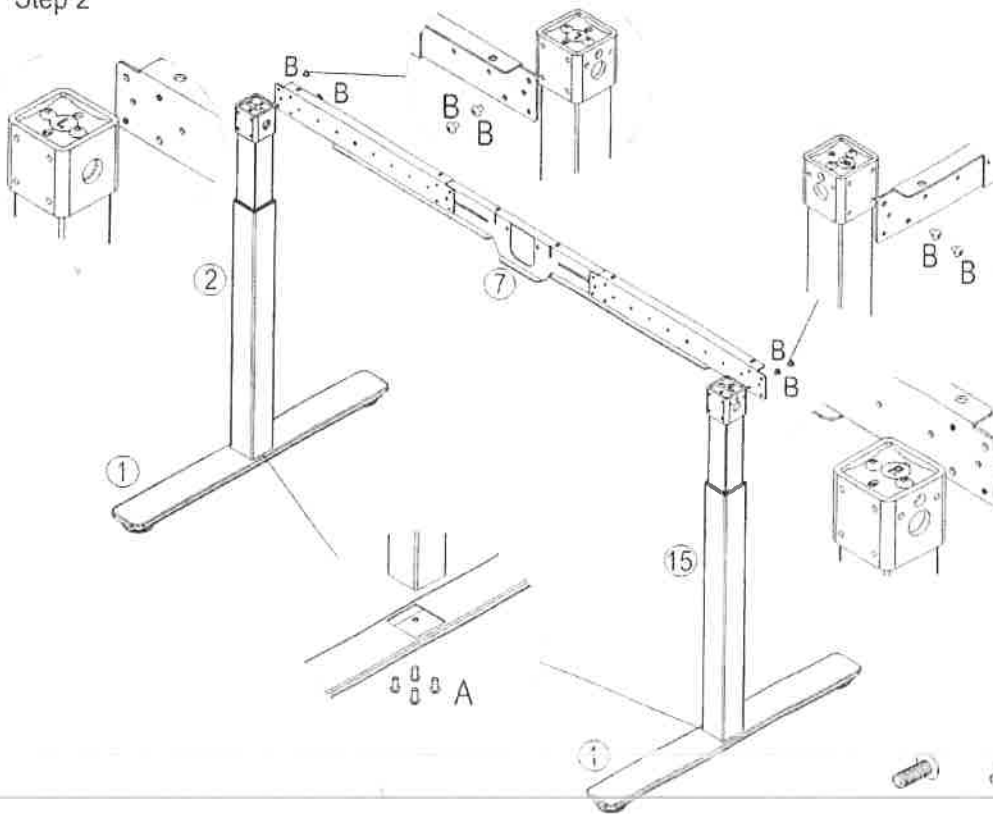

Step 3

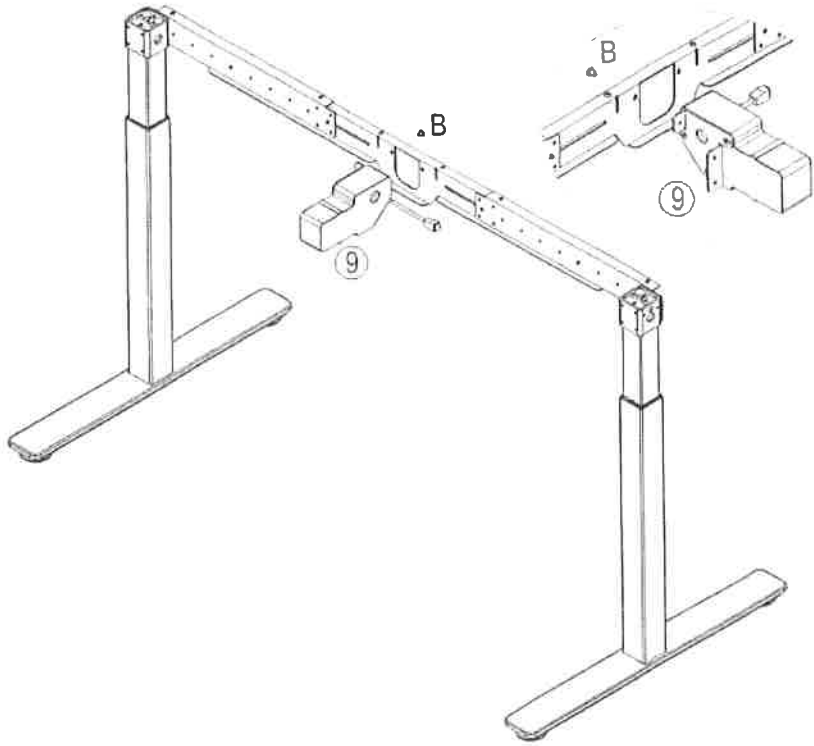

Step 4

Insert hex rod (item 14) into tube (item 11)

Insert tube hex rod (item 11) into leg assembly (item 2 & item 15) until it is flush with outside of leg assembly.

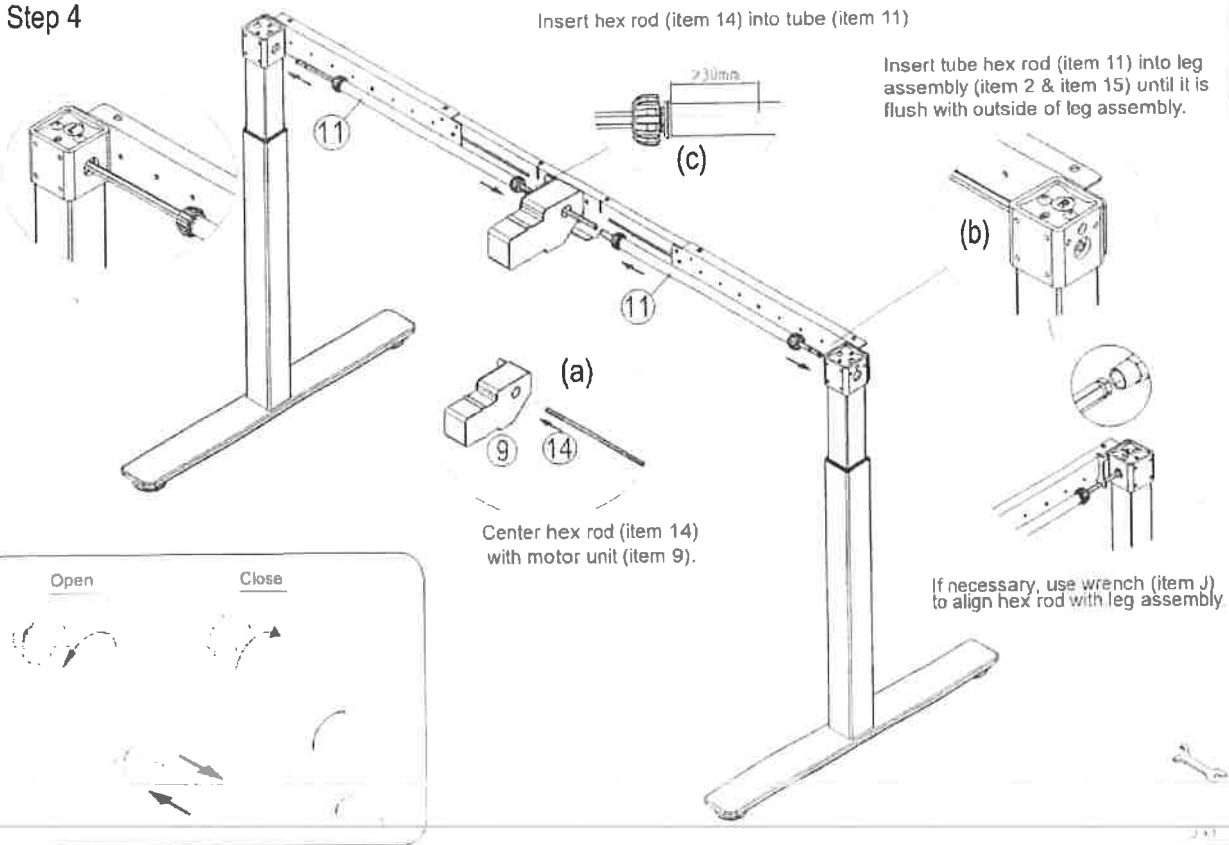

Step 5

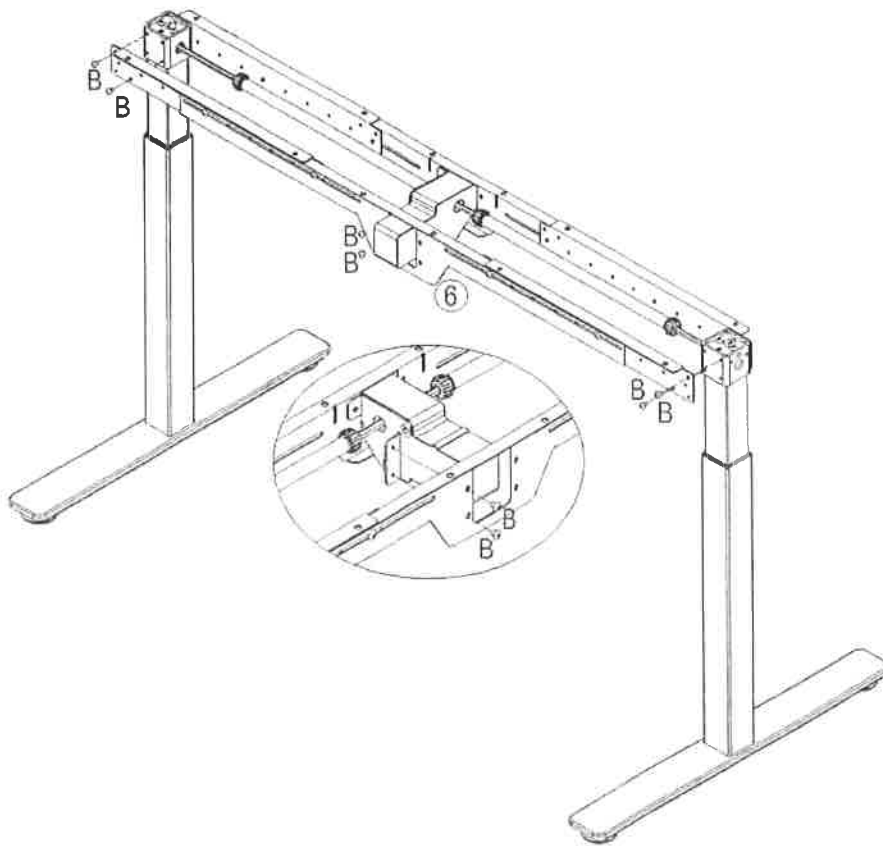

B x6 H x1

Step 6

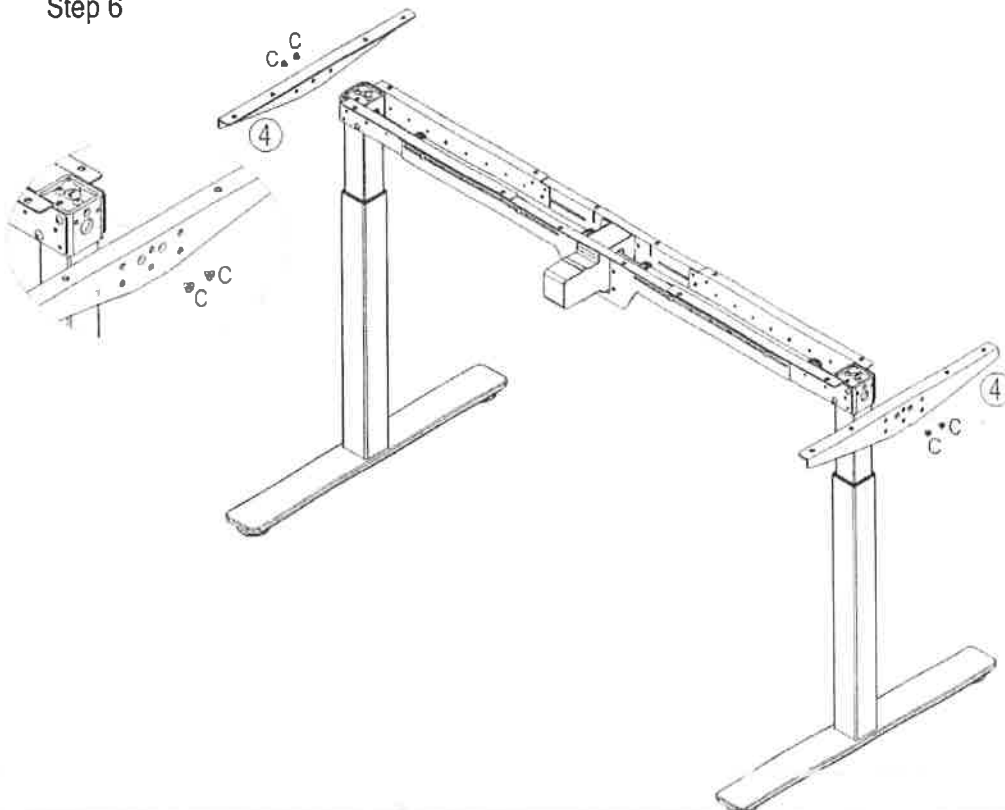

Cx4 Hx1

Step 7

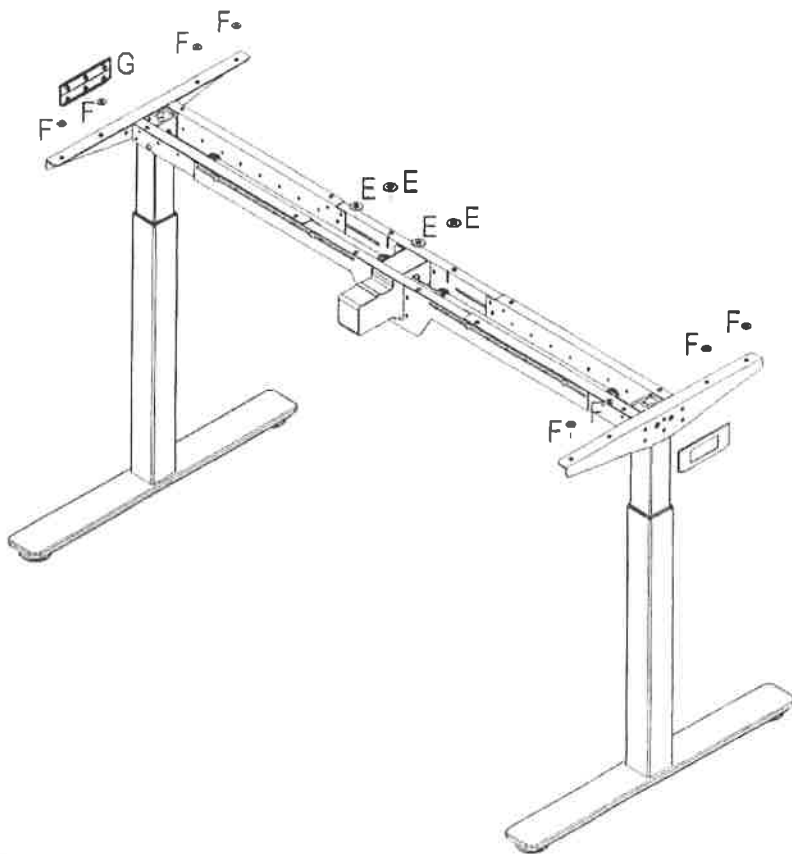

10 of 13

Step 8

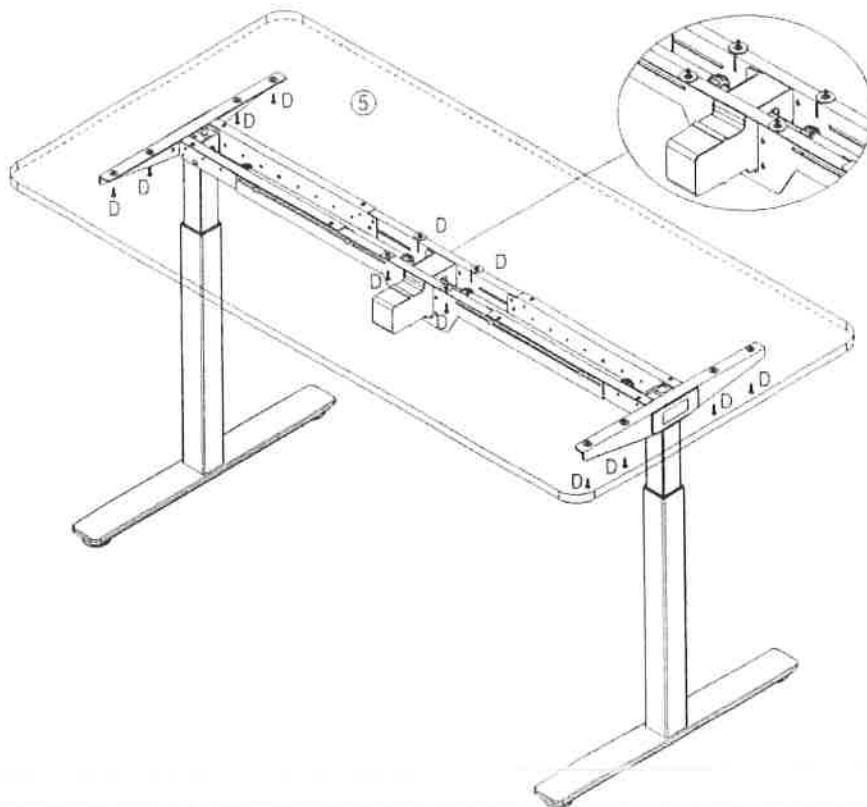

D x12

11 of 13

Step 9

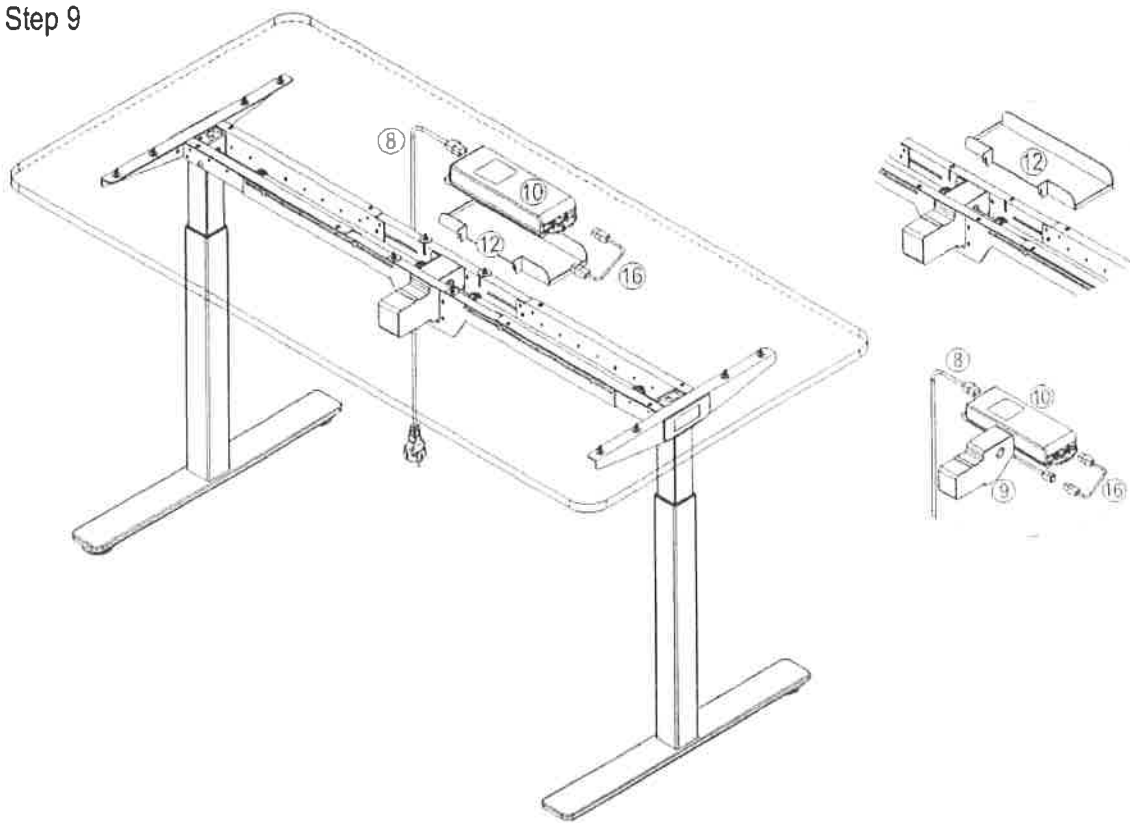

12 of 13

Step 10

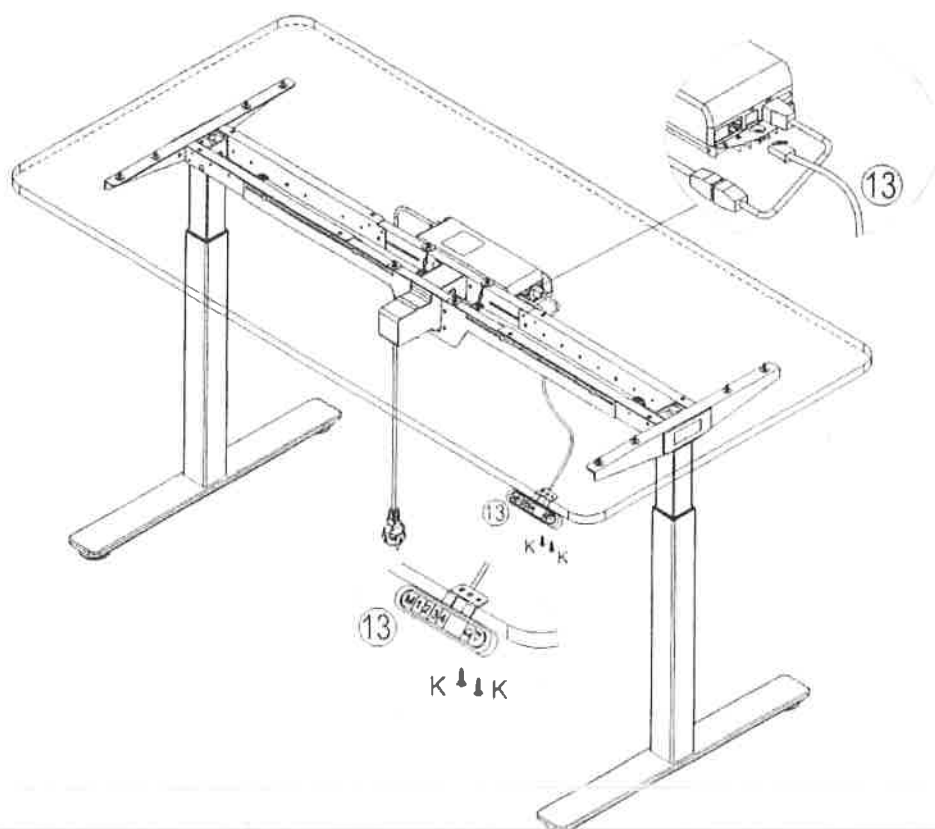

K x2

13 of 13